



ROBERTS®

Floor Covering Installation Tools

**Quality &
Excellence
Since 1938**



World Class...World Wide

2010-2011
CATALOG

SUPPORTING GENERATIONS OF PROFESSIONAL INSTALLERS

SINCE 1938, Roberts Consolidated Industries, Inc. has been a driving force in the continued **MODERNIZATION** of carpet installation techniques. Through constant **INNOVATION**, Roberts has invented and improved many of the most common carpet tools that are in use today. With locations and product lines known and used throughout the world, Roberts has been recognized as the **PREMIER BRAND** of carpet installation tools, adhesives and accessories for **OVER SEVENTY YEARS**. Worldwide, the Roberts name continues to be the choice of installation professionals who demand **QUALITY** and **RELIABILITY** and we renew our commitment to continue to be the worldwide industry leader.

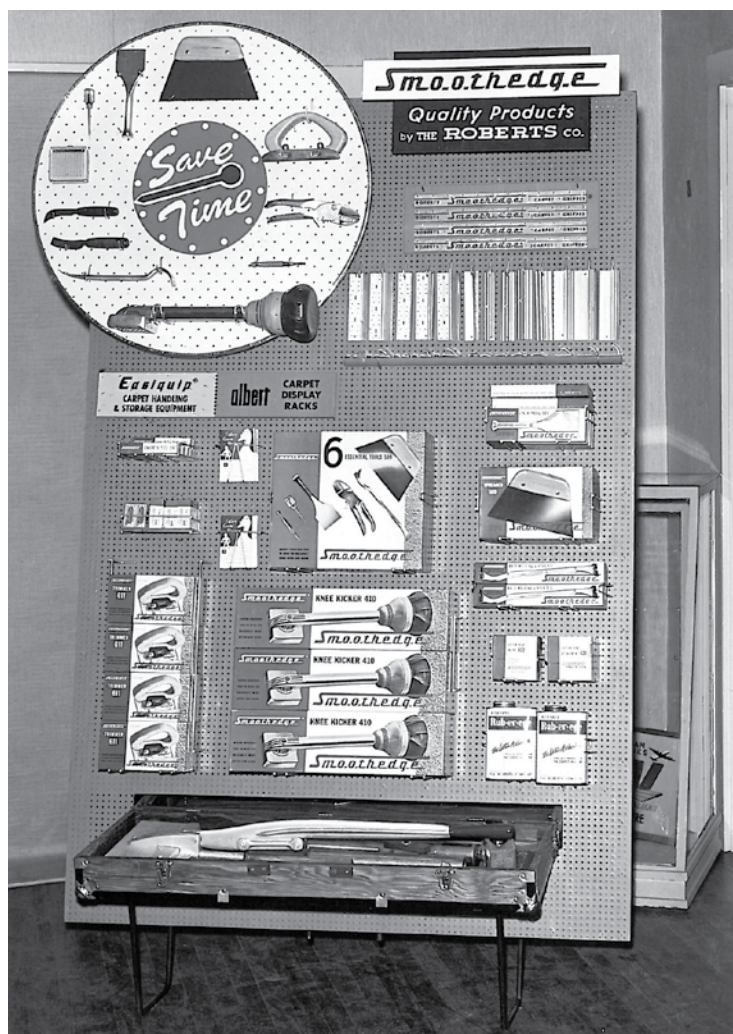

GOLDEN TOUCH, A COMMITMENT TO EXCELLENCE



For over thirty years, Roberts Golden Touch, or "GT" as it is referred to by many installers, has always stood as a symbol of high quality tools. The logo stands as an oath from Roberts to only offer the best products possible. With this line, we are continuing our commitment to excellence by responding to the needs of the true professional. It serves as a tribute to all installers who have come to recognize Golden Touch for its dependability and commitment to quality.

Refer to the Roberts Floor Covering Adhesives catalog for a full listing of flooring adhesives.

Refer to the Harris Wood catalog for a full listing of wood flooring.

Refer to the QEP Installation Tools catalog for a full line of tile and stone installation tools.

1-866-435-8665

TABLE OF CONTENTS



2



10



13



14

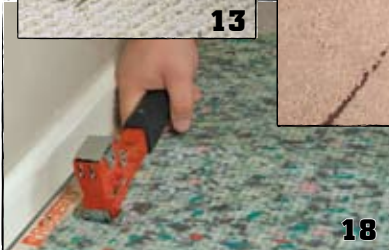

18

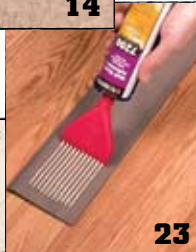

23



20



24



27



26

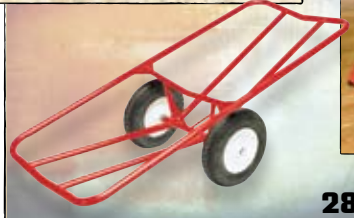

28



29



32

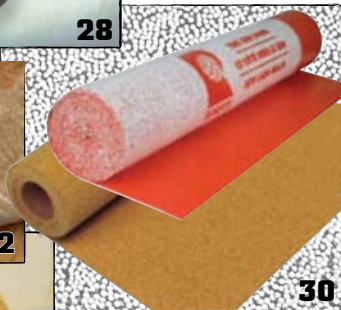

30



32



33

CARPET INSTALLATION

Stretchers & Accessories, Knee Kickers, Heat Irons, Seam Rollers 2 - 9

CUTTERS

Trimmers, Cutters, Stair Tools, Jamb Saws and Blades, Shears, Flooring Knives, Carpet Knives . . 10 - 15

TEAR-OUT TOOLS

Floor Strippers, Scrapers, Carpet Pullers, Molding Lifters, Door Hinge Pin Removers 16 - 17

STAPLERS

Staplers, Hammer Tackers, Staple Hammers 18

INSTALLATION TOOLS

Sharpeners, Tool Boxes, Glue Guns, Heat Guns, Chalk Reels, Nail Driving Bars, Metal Cutters, Hammers, Tape Measures, Carpet Groomers, Knee Pads, Adhesive Accessories, Topset Gouge, Tool Boxes 19 - 23

TROWELS

"Action Grip" & Wood Handles, Economy, Wall Base 24 - 25

ROLLERS

Carpet/Linoleum Rollers, Floor Rollers 26

VCT TOOLS

Vinyl Tile Cutters, Seam Rollers 27

MATERIAL HANDLING EQUIPMENT

Dollies, Carts, Gliders, Slides, Lifters 28

LAMINATE TOOLS

Laminate Cutters, Pull Bars, Tapping Block, Laminate Wedge Spacers 29

UNDERLAYMENT

Sound Resistant, Moisture Resistant, Waxed Paper, Cork 30 - 31

SURFACE PROTECTION & TAPES

Carpet Protection, Hard Surface Protection, Rhino Grip for Vinyl, Carpet, Traction, and Duct Tape 32

BLADES & NAILS

Blades, Nails, Staples 33

Roberts®, Harmony® and Cool Shield® are registered trademarks of Roberts Consolidated Industries, Inc.

Q.E.P.® is a registered trademarks of Q.E.P. Co., Inc.

Rhino Grip™, Protect-IT™, Golden Touch™ and Unison™ are trademarks of Roberts Consolidated Industries

LEXAN® is a registered trademark of General Electric Company

Velcro® is a registered trademark of Velcro Industries B.V. Ltd Liab Company

CRI® is a registered trademark of The Carpet and Rug Institute Corporation

DUO-FAST® is a registered trademark of Illinois Tool Works Corporation

PROFESSIONAL STRETCHERS

POWER-LOK STRETCHER



10-254V

The 10-254V Value Kit includes: one power unit, tail block with wheels, six 3' extension tubes, adjustable locking tube, transfer tube and the complete interlocking wheeled stretcher carrying case and tube carrying case

The Power-Lok Stretcher is the most advanced power stretcher available.

- Power-Lok swivel head locks into 17 different "stretch/pattern holding" positions
- Unique swivel head for stretching angles or corners
- Variable pin penetration for different carpet thicknesses
- Low profile head with sidekicking platform makes it compatible with a knee-kicker
- Steel handle on head for better grip and repositioning
- Standard 18" tail block includes a foam wall protector and wheels for easy repositioning
- Stretch up to 38' with the Value Kit and up to 23-1/2' with the standard set

The Power-Lok Stretcher is also available as a standard set

- A standard 10-254 set includes: one power unit, tail block with wheels, three 3' extension tubes, adjustable locking tube, transfer tube, and the single interlocking wheeled stretcher carrying case

10-254V Power-Lok Stretcher Value Kit

10-254 Power-Lok Stretcher

10-254-50 Replacement Power Head for 10-254 (does not include tube, tail block or carrying cases)

FREE with each stretcher!
No. 10-250 Adjustable Locking Tube

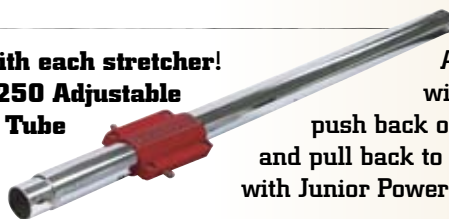

Adjust your stretcher poles in a flash with our Adjustable Locking Tube! Just push back on your tubes to extend, push buttons and pull back to shorten. Also sold separately. Works with Junior Power Stretchers with standard size poles.

10-254, 10-254V

Note: See page 4 and 5 for accessories.

JUNIOR POWER STRETCHER



10-237V

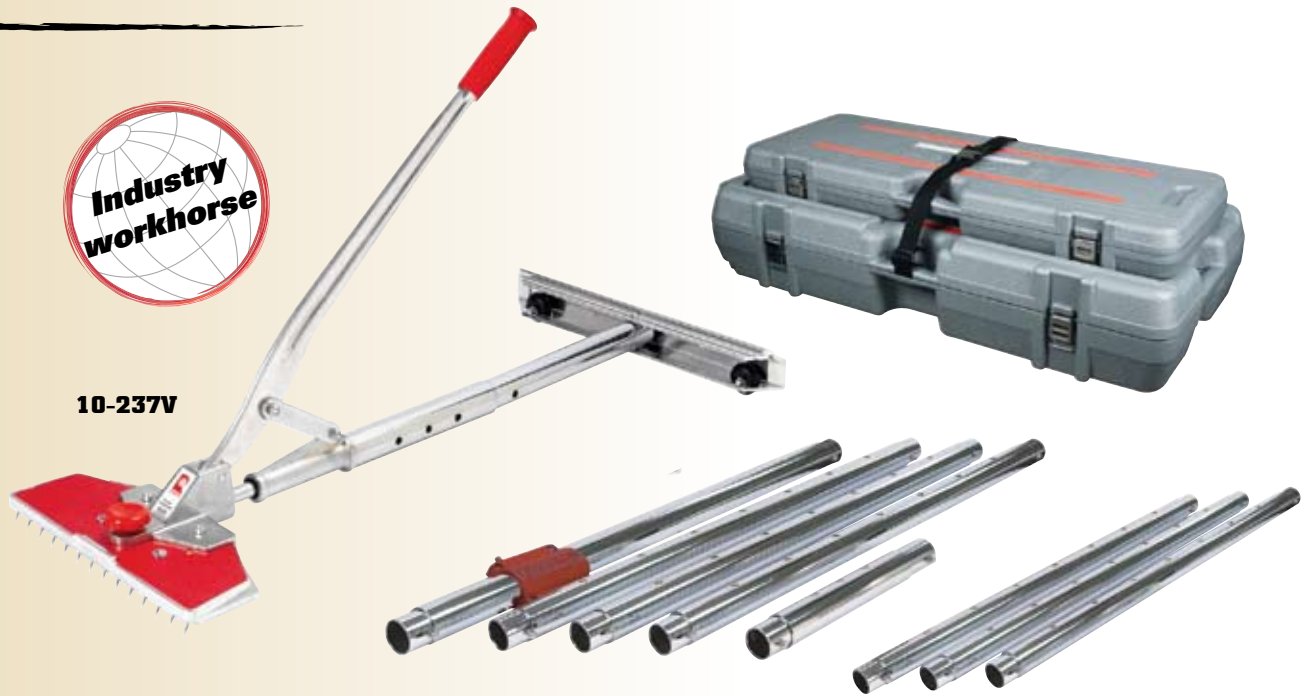

The 10-237V Value Kit includes: one power unit, tail block with wheels, six 3' extension tubes, adjustable locking tube, transfer tube and the complete interlocking wheeled stretcher carrying case and tube carrying case

Our most economical power stretcher is loaded with features.

- The low profile head is easy to span with the knee kicker
- 18" spring-loaded tail block with wheels provides additional support
- Stretch over 38' with the Value Kit and up to 23-1/2' with the standard set

The Junior Power Stretcher is also available as a standard set.

- A standard 10-237 set includes: one power unit, tail block with wheels, three 3' extension tubes, adjustable locking tube, transfer tube, and the single interlocking wheeled stretcher carrying case

10-237V Junior Power Stretcher Value Kit

10-237 Junior Power Stretcher

10-237-50 Replacement Power Head for 10-237 (does not include tube, tail block or carrying cases)

FREE with each stretcher!
No. 10-250 Adjustable Locking Tube

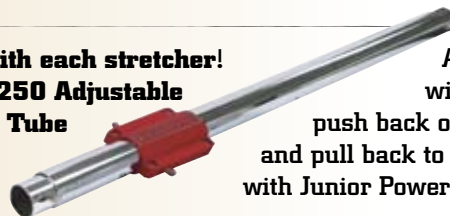

Adjust your stretcher poles in a flash with our Adjustable Locking Tube! Just push back on your tubes to extend, push buttons and pull back to shorten. Also sold separately. Works with Junior Power Stretchers with standard size poles.

10-237, 10-237V

Note: See page 4 and 5 for accessories.

STRETCHERS & ACCESSORIES

LOCKING PATTERN MATCHING AND SEAM REPAIR STRETCHER



The unique locking action enables "hands-off" seam repair. Turn the Automatic Locking Mechanism "ON" and the powerhead locks each 1/4" of pin plate travel for easy pattern alignment. Turn the locking action "OFF" and the stretcher works in the conventional "non-locking" mode.

- Adjustable pin depths for different carpet thicknesses
- Holds up to 300 lbs. of stretch tension.
- Tailblade swivel construction allows for angle stretching in any direction off of tackstrip
- Solid die cast frame stands up to years of dependable service
- ON/OFF knob provides locking or conventional operation
- Custom molded carrying case

10-128

- 10-128 Locking Pattern Matching and Seam Repair Stretcher**
- 10-117-04 Powerhead Replacement Unit**
- 10-107-03 Tailblade Replacement Unit**
- 10-117-05 Replacement Blow Molded Carrying Case**

STRETCHER CASES



10-230-40



10-230-41



10-230-3K

The Roberts Stretcher Case System consists of a Stretcher Case with Wheels and a Tube Case that hooks onto the Stretcher Case with Wheels for easy transportation. The cases are easily split apart to equally distribute the weight when carrying to and from the jobsite. Both cases include high-density blow molded plastic walls for exceptional durability, recessed hinges and latches and comfortable molded handles.

- Stretcher Case with 4" Wheels holds stretcher unit, tail block with wheels, three 3' extension tubes, adjustable locking tube and transfer tube (nylon web belt with quick release buckle included)

- 10-230-40 Empty Stretcher Case with Wheels**
- 10-230-41 Empty Tube Case (holds four 3' tubes)**
- 10-230-3K Tube Case with Three 3' Extension Tubes**

10-230-40, 10-230-41, 10-230-3K

ADDITIONAL STRETCHER TUBES

- Fits all Roberts Stretchers except the Super Senior Power Stretcher 10-222, as well as most other standard carpet stretchers

- 10-250** Adjustable Locking Tube
- 10-230-10** 3' Steel Stretcher Tube Fits 10-254 & 10-237 Stretchers
- 10-235-10** 3' Aluminum Stretcher Tube (not shown)
- 10-235-05** 5' Aluminum Stretcher Tube (not shown)

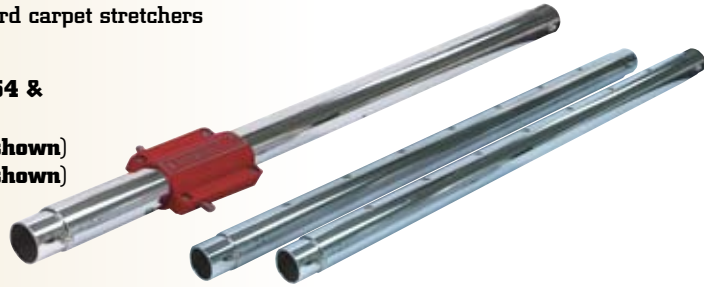

10-250, 10-230-10, 10-235-10, 10-235-05

TUBE CARRYING CASE

For 3' Stretcher Tubes

- Holds 6 tubes, aluminum or steel
- Made of ballistic nylon with extra padding
- Heavy duty zipper, shoulder strap and carry handle



10-232

NAP GRIP HEAD (COTTON HEAD)

- Designed to use on low profile loop, cut pile and woven carpets

- 10-248** Nap Grip Head for 10-254 and 10-237 stretchers
- 10-222-01** Nap Grip Head for Super Senior Power Stretcher



10-248, 10-222-01

POWER STRETCHER TAIL

- Needle sharp point bites through carpet and pad into wood subfloor for a firm solid stretch
- Stretch even when there are no walls to brace against
- Precision made with hand-ground tempered steel
- Fits all Roberts Stretchers except the Super Senior Power Stretcher 10-222



10-258

CARPET SPREADER

- Tucks carpet neatly into gully while power stretching
- Sturdy oak handle
- Solid steel blade with tapered edges will not catch or pull carpet face yarn



10-562

KNEE KICKERS

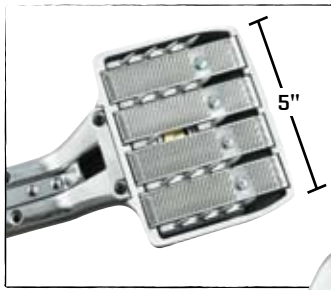

GT2000 XL KNEE KICKER

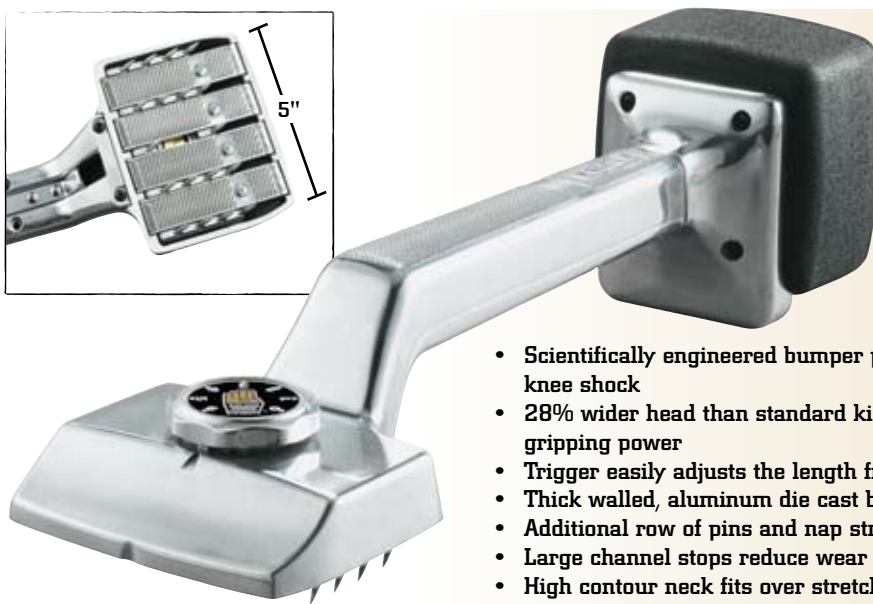

- Scientifically engineered bumper pad significantly reduces knee shock
- 28% wider head than standard kickers provides 33% more gripping power
- Trigger easily adjusts the length from 18½" to 22½"
- Thick walled, aluminum die cast body for maximum strength
- Additional row of pins and nap strip offer more gripping surface
- Large channel stops reduce wear and maintain precise opening range
- High contour neck fits over stretcher
- Center grooved head for adjusting power stretcher head
- Smooth, precise dial adjustments



10-2000GT

10-2000GT
10-2000-09

GT2000 XL Knee Kicker
Replacement Bumper Pad (3" thick)



GT KNEE KICKER

- Easy one button adjustments from 18-7/8" to 24" lengths
- Extra wide head for improved load distribution
- High contour neck for use over stretcher head and poles
- Center grooved head for adjusting power stretcher head
- Easy to read, easy to adjust pin depth dial



10-501

10-450-22
10-412-09
10-2000-09

Optional Molded Carrying Case
Replacement Bumper Pad (2" thick)
Replacement Bumper Pad (3" thick)



DELUXE KNEE KICKER

The 10-412 Deluxe Knee Kicker is Roberts' most popular knee kicker and has been the "industry standard" for over 25 years.

- Trigger assembly easily adjusts the length from 17" to 21"
- Superior die cast aluminum body is lightweight and durable
- Exclusive non-slip checkered hand grip
- Foam-filled seamless bumper pad for extra comfort
- Easy to read, easy to adjust pin depth dial
- Center grooved head for adjusting power stretcher head
- All 10-412K kickers come complete with a custom molded carrying case



10-412-2

10-412-2
10-412K
10-412BKK
10-412-22
10-412-09
10-2000-09

Deluxe Knee Kicker (no case)
Deluxe Knee Kicker with Case
Deluxe Knee Kicker (black finish with case)
Optional Molded Carrying Case
Replacement Bumper Pad (2" thick)
Replacement Bumper Pad (3" thick)

KNEE KICKERS

DELUXE HIGH PROFILE KNEE KICKER

The 10-422BK features the same solid construction and reliability of the 10-412 but with the added value of a number of installer-designed features.

- High contour neck for use over stretcher head and poles
- 50% thicker bumper pad for extra knee comfort
- 16% wider head for improved load distribution
- Solid, dependable trigger release adjusts from 17-1/2" to 21-1/2"
- Exclusive non-slip checkered hand grip
- Center grooved head for adjusting power stretcher head

- 10-450-22** Optional Molded Carrying Case
- 10-412-09** Replacement Bumper Pad (2" thick)
- 10-422-09** Replacement Thick Bumper Pad (3" thick)
- 10-2000-09** Replacement Bumper Pad (3" thick)



10-422BK

ECONO ADJUSTABLE KNEE KICKER

- Double locking pins to easily adjust length from 19" to 23"
- Extra heavy aluminum casting and industrial grade steel provide rugged strength
- High contour neck for use over stretcher head and poles
- Center grooved head for adjusting power stretcher head
- Easy to read, easy to adjust pin depth dial
- Durable powder coated finish

- 10-450-22** Optional Molded Carrying Case
- 10-412-09** Replacement Bumper Pad (2" thick)
- 10-2000-09** Replacement Bumper Pad (3" thick)



10-410

REPLACEMENT BUMPER PADS FOR KNEE KICKERS

- 10-412-09** Replacement Bumper Pad (2" thick)
- 10-422-09** Replacement Thick Bumper Pad (3" thick)
- 10-2000-09** Replacement Bumper Pad (3" thick)



10-412-09, 10-422-09, 10-2000-09

OPTIONAL CASES FOR KNEE KICKERS

- 10-412-22** Optional Molded Carrying Case for 10-412
- 10-450-22** Optional Molded Carrying Case for 10-501, 10-422BK, and 10-410



10-412-22, 10-450-22

SHARKTEETH KNEE KICKER GRIPS

The hardened stainless steel blades last 5 times longer than conventional nap grips. The long pins penetrate deep into pile to positively grip all carpet types.

- Fits all knee kickers with single screw nap grips
- Hardened stainless steel blades will not bend
- Easy to clean
- One set of three per bag

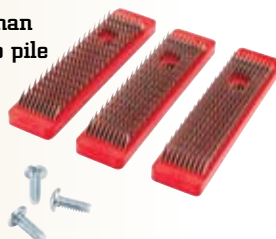

10-245

HEAT BOND IRONS

The coolest
heat shield
on the
market

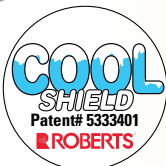

10-482G

COOL SHIELD® HEAT BOND IRON

The Cool Shield Heat Bond Iron melts heat bond tape quickly and easily while maintaining a cooler top shield temperature. Even on the highest setting of 425°F the 482G reaches a maximum heat shield temperature of only 256°F.

- Patented double heat shield minimizes deforming of carpet backing and face yarn
- "S" shaped heating element provides even heating and longer heat retention
- Grooved no stick base for fast, easy clean-up
- "Comb Profile" forms ridges in adhesive for stronger carpet seams
- Streamlined, low profile design allows for easy carpet seaming
- 3-way cord guide keeps the 9-1/2' cord out of the way
- Thermostat indicator light shows when iron is heating

The true
workhorse



10-282, 10-282G-2

DELUXE HEAT BOND IRON

This best selling Heat Bond Iron is the first choice of professionals worldwide.

- Streamlined, low profile design allows for easy carpet seaming
- Even heat distribution for thorough melting
- Heat shield to prevent backings from overheating
- No stick coated for fast, easy clean-up
- "Comb Profile" forms ridges in adhesive for stronger carpet seams
- 3-way cord guide keeps cord out of the way
- Stay-cool handle and up-front thermostat make it easy to use
- Approximate heat range 135°F to 425°F

10-282 Deluxe Heat Bond Iron, Flat Base
10-282G-2 Deluxe Heat Bond Iron, Grooved Base

For 6"
tape



10-286G

6" HEAT BOND IRON

Get faster, more thorough bonding even near walls or in doorways.

- Custom designed to distribute heat evenly from front to tail
- Special contoured handle stays cool
- Grooved no stick base for fast, easy clean-up
- Up-front thermostat control for easy heat-setting adjustments
- Low profile, tapered base plate design for joining carpet easily at the back of the iron
- 3-way cord guide keeps cord out of the way
- Approximate heat range 135°F to 425°F
- Includes holding tray

STANDARD SEAM ADHESIVE APPLICATOR

- Designed to apply seam sealer to carpet backs
- Applicator nozzle on 8 oz. plastic squeeze bottle



10-145

SEAM ROLLERS

4" LOOP PILE SEAM ROLLER

- Extended, angled soft grip handle for better leverage
- Specifically designed for seaming loop pile and berber carpets
- Star wheels maximizes hot melt transfer into carpet back for stronger seams
- Excellent for hooking carpet on tackstrip



10-169

CARPET SEAM ROLLER

- Specially designed for loop pile carpet
- Wide head reduces dishing in seam area
- Durable and lightweight superior die cast handle
- Get stronger seams and increased hot melt transfer into carpet back with stationary roller shaft



10-105



10-100

4½" DELUXE CARPET SEAM ROLLER

- Specially designed for loop pile carpet
- Professionally finishes even the most demanding carpet seams
- No-slip handle and lightweight design to minimize user fatigue
- Offset, extra wide 4-1/2" rollers to reduce seam peaking and maximize adhesive penetration for stronger, longer lasting seams



10-101

3" CARPET TRACTOR (CANADA ONLY)

- Professionally finishes even the most demanding carpet seams
- Three 3" zinc plated rollers to reduce seam peaking and maximize adhesive penetration for stronger, longer lasting seams
- Comfortable wooden handle minimizes user fatigue



10-098

4" CUT PILE SEAM ROLLER

- Extended, angled soft grip handle for better leverage
- Smooth roller forces carpet backing into seaming tape without fraying yarn ends
- Specifically designed for safe seaming of cut pile carpets, saxonomies and vinyl seams



10-170

3½" SOLID WHEEL CARPET SEAM ROLLER

- Smooth roller is specifically designed for safe seaming of cut pile carpets and saxonomies
- Reduce "pocking" and deformation of carpet yarn with solid nylon rollers
- Rugged steel frame
- Specially designed handle for optimum leverage



10-106-3

4½" DELUXE SMOOTH CARPET SEAM ROLLER

- Professionally finish seams and eliminate pock marks in short nap velvet-like carpets
- Work longer with less fatigue using the comfortable plastic-coated handle
- Extra wide 4-1/2" rollers that extend beyond heat bond tape to reduce seam peaking and dishing
- Great for use with sheetgoods and VCT



10-102

TRIMMERS & CUTTERS



10-621GT



GT ONE-STEP CARPET TRIMMER

- Secures, cuts and tucks carpet in one easy step
 - Easily cuts a variety of carpet thicknesses with the adjustable blade guide
 - Roller system tucks carpet into gulley
 - 2" star rollers secure carpet to tackstrip
 - Use with knee kicker or stretcher and speed up installation
- Uses replacement blades: 10-388, 10-444, 10-445**



10-616-2

CONVENTIONAL CARPET TRIMMER

- Quickly trims carpet neatly at the wall and under toe kicks
- Five position folding handle moves easily in hard to reach areas
- Quick and positive vertical and horizontal adjustment
- Anti-slip rubber handle and hardened stainless steel guide
- Includes 20 heavy duty slotted blades

10-906 Carpet Trimmer Adapter

*Uses replacement blades: 10-388, 10-444, 10-445**



10-905

MULTI-PURPOSE WALL TRIMMER

This Multi-Purpose Wall Trimmer is not only good for cutting conventional carpet, it is great for cutting soft vinyl sheetgoods, carpet tiles and cushion back for glue-down carpets.

- Make cleaner cuts without marking walls
- Hooked blades can be used to cut carpet tiles quickly and easily
- Slotted blades can be used for regular carpet or vinyl sheetgoods
- Snap-on anti-friction boot glides smoothly over sheetgoods
- Fully adjustable for most material thicknesses
- Stainless steel construction

*Uses replacement blades: 10-440, 10-441, 10-436, 10-437, 10-438**

Includes 15 Heavy Duty Slotted Blades



10-152-3

10-152GT



LOOP PILE CUTTER

- Efficiently cuts most loop pile carpet regardless of thickness
- Unique two-blade design accommodates both left and right positions for cutting closer to the yarn edge
- "Direct Contact" locking design keeps blades securely in place
- Throat opening adjusts automatically for different carpet backs
- Constructed of stainless steel for maximum durability

*Uses replacement blades: 10-436, 10-437, 10-438**

Includes 15 Heavy Duty Slotted Blades



10-146-3

10-146GT



CUSHION BACK CUTTER

- Cut all thicknesses of cushion-back carpet and conventional carpet with adjustable blade depth
- Two blades that lock into position for close, precise cutting
- Direct-pressure blade knob holds blades tightly in place
- Constructed of stainless steel for maximum durability

*Uses replacement blades: 10-436, 10-437, 10-438**

*Refer to page 33 for a complete listing of replacement blades.

CUTTERS & STAIR TOOLS

CUSHION BACK CUTTER WITH ROW FINDER

- Same features as the 10-146-3 with the added benefit of patented row finder attached
- Quick and easy method to find the row and cut in one time-saving motion
- Includes 15 Heavy Duty Slotted Blades

*Uses replacement blades: 10-436, 10-437, 10-438**



10-147

LOOP PILE CUTTER

- Single center mechanism holds both slotted and utility blades in place
- New, stronger base design
- Superior double usage - use slotted blade for top cutting or trimmer blade for bottom cutting
- 50° blade angle permits cleaner, smoother precise cuts
- Quick release blade replacement feature for fast blade changes
- Extra long nose provides for better row separation
- Accepts all standard utility blades

Uses replacement blades: 10-388, 10-436, 10-437, 10-438



10-154-3

ROW FINDER

- Use to separate carpet rows to minimize damage to nap and loops
- Features tapered round end for cut pile and flattened end for loop pile carpets
- Slip resistant checkered grip



10-517

EZ TUK CARPET TUCKER

- Lightweight nylon tucking tool will not mark or damage walls
- Use around toilets and ceramic tile without fear of breakage
- Square edge works well for tucking carpet into corners
- Curved edge is great for stairs
- 3-1/2" wide blade



10-522-4

STAIR TOOLS

- Use to set carpet into tack strip, drive carpet into gullies and crease carpet along wall line
- Heavy duty blade easily sets carpet into stairway crevices
- Made from forged, chrome-plated steel

10-520 **2-3/4" Stair Tool**
10-521 **3-1/2" Extra Wide Stair Tool**



- New tapered edge
- Ergonomic, vibration-resistant, soft grip handle

10-521

10-520

10-135 AWL - 4" / 10-136 TURNING TOOL (CANADA ONLY)

- Hundreds of uses for both tools. 10-136 is ideal for tucking carpet at baseboards as well as use for upholstery work. Cushion grip adds comfort to utility
- Precision ground shaft of tempered steel. The last inch of 10-136 shaft is bent at a 30° angle



10-135, 10-136

*Refer to page 33 for a complete listing of replacement blades.

JAMB SAWS

LONG NECK 6" JAMB SAW



- Extended "tail" for maximum leverage against torque
- Powerful, 1050 watt industrial grade power unit
- Patented design enables saw to cut full inside corners in molding up to 1/2" thick
- Adjustable cutting depth guide prevents cutting into plaster or wall board when trimming base boards
- Easy access trigger for better control
- Precision height adjustment from "flush" to 1-1/16"
- Doors as thick as 1-3/4" can be undercut without removal
- Includes 6-3/16" 36-tooth carbide tip blade and masonry blade
- Custom molded carrying case

10-55

10-47-2 6-3/16" 36-Tooth Carbide Tip Saw Blade
10-47-6 6-3/16" 20-Tooth Carbide Tip Saw Blade
10-55-24 Masonry Blade



SUPER SIX 6" JAMB SAW

- Adjustable cutting depth guide prevents cutting into plaster or wall board when trimming base boards
- Powerful, 900 Watt industrial grade power unit has all ball and needle bearings
- Patented design enables saw to cut full inside corners in molding up to 1/2" thick
- Spiral ground gears for smooth, quiet operation
- Precision height adjustment from "flush" to 1-1/16"
- Doors as thick as 1-3/4" can be undercut without removal
- Includes 6-3/16" 36-tooth carbide tip blade
- Custom molded carrying case

10-46

10-47-2 6-3/16" 36-Tooth Carbide Tip Saw Blade
10-47-6 6-3/16" 20-Tooth Carbide Tip Saw Blade



REPLACEMENT BLADES

10-47-6

Carbide tipped blades provide long cutting life
 20-tooth anti-snag blade resists catching on hidden nails

10-47-2

36-tooth carbide tipped blade easily cuts through tough wood. Excellent for cutting door jams, baseboards and along walls

10-55-24

Durable masonry blade easily cuts through brick and cement block

10-47-6, 10-47-2, 10-55-24

1-866-435-8665

SHEARS

CARPET SHEARS

- Made in Germany from the finest quality high carbon steel
- Precision ground cutting blades
- Superior cutting ability and durability
- Accommodates large hands comfortably with extra wide, vinyl coated cushioned handle openings
- Blade edge sharpens easily on stone
- High polished steel finish



10-123

8" NAPPING SHEARS



Side angle profile

- Made in Germany from the finest quality high carbon steel
- Offset handle for easy, level napping
- Cushioned, vinyl coated handles for comfort
- Precision ground cutting blades
- High polished steel finish



10-121

6" DUCKBILL NAPPING SHEARS

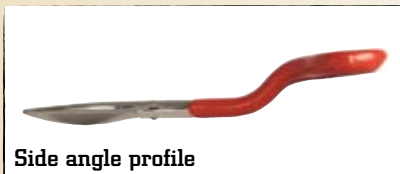

Side angle profile

- Made in Germany from the finest quality high carbon steel
- Offset handle and special blade prevent gouging while napping
- Cushioned, vinyl coated handles for comfort
- Precision ground cutting blades
- High polished steel finish



10-585

8" DUCKBILL NAPPING SHEARS



Side angle profile

- Made in Germany from the finest quality high carbon steel
- Offset handle and special blade prevent gouging while napping
- Cushioned, vinyl coated handles for comfort
- Precision ground cutting blades
- High polished steel finish



10-586-3



reddot design award

The quality seal for superior design awarded annually to products of sophisticated and innovative design by an international jury of experts



ROLL-O UNIVERSAL KNIFE



Roller glides over rough materials



10-208C

- Large patented roller glides over rough materials such as roofing shingles, carpet, sheetgoods, linoleum and more
- Big Grip Handle - Extended tail protects knuckles and provides firm grip
- Steel Reinforcements in nose and tail wear areas
- Push Button Opening - Quick and easy blade changing and storage access
- Blade Storage holds 10 extra blades (not included)
- Uses standard 2 or 3 notch utility and hook blades

10-208C Roll-O Universal Knife Sheath

10-208-3

PROFESSIONAL FIXED BLADE UTILITY KNIFE



- Lightweight and heavy duty to cut all types of flooring, including carpet, padding, linoleum and sheet vinyl
- Easy-open knob with bail to make blade changes more convenient
- Checkered handle for a slip resistant grip
- Uses standard replacement blades with 1, 2 or 3 positioning slots on top
- Handle stores additional standard or heavy duty utility blades
- Includes 3 blades

10-920-6

*Uses replacement blades: 10-434, 10-388, 10-444, 10-445**

BIG FATSO MULTI-PURPOSE KNIFE



- Cuts vinyl, linoleum, sheet vinyl and carpeting
- Constructed of die cast aluminum
- Offset head gives knuckle room and convenient, precise cutting angle
- Large contoured handle for comfort
- Unscrew end cap and swing open for quick and easy blade change
- Uses most standard utility and hook blades with 2 or 3 positioning slots on top
- Handle stores additional standard or heavy duty utility and hook blades
- Includes 3 blades

10-218

*Uses replacement blades: 10-434, 10-440, 10-441**

*Refer to page 33 for a complete listing of replacement blades.

1-866-435-8665

PROFESSIONAL CARPET KNIFE

- Special thumbstop design provides safety and increased cutting pressure
- Easy push button blade changing
- Knurled grip assures firm grip
- Includes 3 slotted blades



Push-button for changing blades



*Uses replacement blades: 10-436, 10-437, 10-438**

10-252

RAZOR BLADE KNIFE

- Features safety guards to keep blade firmly in place
- Easy-open knob with bail to make blade changes more convenient
- Checkered handle for a slip resistant grip
- Rugged lightweight precision die cast aluminum
- Handle stores additional heavy duty slotted blades, 3 blades included

*Uses replacement blades: 10-436, 10-437, 10-438**



10-215

SLOTTED BLADE CARPET KNIFE

- Contoured handle for precise cutting
- Finger blade guard
- Extra blade storage
- Includes 2 slotted blades

*Uses replacement blades: 10-436, 10-437, 10-438**



10-253

CUT & JAM CARPET KNIFE

- Patented, unique dual function design, use one end to cut carpet and the other to jam carpet into gullies
- Features an easy-open knob with bail, safety thumb and blade guards
- Checkered handle for a slip resistant grip
- Rugged lightweight precision die cast aluminum
- Handle stores up to 10 additional heavy duty slotted blades, three blades included

*Uses replacement blades: 10-436, 10-437, 10-438**



10-220

LINOLEUM KNIFE

- Cuts linoleum, vinyl sheetgoods
- Heavy gauge, high carbon steel blade
- Makes accurate, even cuts without burrs
- Soft, comfort grip handle with hang hole
- Double edge sharp blade will provide years of perfect cuts



10-931

**Refer to page 33 for a complete listing of replacement blades.*

FLOOR STRIPPER MACHINE



Best cutting
action for
every
tear-out job

- For removal of VCT, sheetgoods, glued-down carpet, general clean up and floor preparation
- Patented adjustable blade orbit pattern - allows operator to select a range of blade motion from "slicing" to "chopping" for optimal performance
- Powerful 120 volt, 12 amp, 1 HP motor
- Extra large curved front plate to guide flooring for smooth removal
- Adjustable wheel height provides best blade angle for any removal job
- Positive locking handle height adjustment
- 9 foot, 14 gauge heavy duty power cord
- Removable handle and weight block, for easy transport and storage
- Includes two double edge blades (4" and 6")
- 35" L x 39" H x 17" W (when assembled)
- Weighs 95 lbs.

10-475

10-475-50 4" x 4" Double Sided Blade

10-475-51 6" x 4" Double Sided Blade

HEAVY DUTY 6" CONVERTIBLE SCRAPER



- Dependable heavy duty scraper easily converts to a stand-up scraper with the addition of a stretcher extension tube (not included)
- "Action lock" handle adjusts 360° to any position
- Comfortable molded handle maximizes thrust and conserves energy
- Includes a 6" hardened steel blade, heavy duty cast aluminum scraper head and a hardened steel locking cam
- Add 3' stretcher extension tubes to achieve desired length

10-195

10-195-01 6" Hardened Steel Replacement Blade

10-230-10 3' Steel Stretcher Tube

HEAVY DUTY 4" SCRAPER



- Efficiently removes tile, adhesive, carpet and other flooring materials
- Lightweight, heavy duty aluminum construction
- 17" long
- Includes one 4" hardened carbon steel, double-sided blade
- Uses 10-455 Double-sided 4" Scraper Blades

10-196

10-455 Double-sided 4" Scraper Replacement Blade

*Refer to page 33 for a complete listing of replacement blades.

1-866-435-8665

TEAR-OUT TOOLS

FLOOR/WALL SCRAPERS

- Angled head provides "clean shaving" cutting action, perfect for stripping floors, walls and wallpaper
- Features three blade clamp screws for maximum blade holding power and flex-grip anti-fatigue vinyl hand grip

- 10-194** 4" Floor/Wall Scraper - 12" handle
- 10-294** 4" Floor/Wall Scraper - 18" handle
- 10-442** 4" Floor/Wall Scraper Replacement Blade (10 pcs.)
- 10-457** 4" Floor/Wall Scraper Replacement Blade (100 pcs.)



10-194, 10-294

STAND-UP SCRAPER

- Professional stand-up scraper
- Steel shank molded into head, welded to steel handle
- Deluxe cushioned grip handle, adjustable from 3' to 6'
- Sturdy construction with an 8" hardened steel blade and locking cam
- Features a 15° angled head

- 10-458** 8" Floor/Wall Scraper Replacement Blades (10 blades)
- 10-458B** 8" Floor/Wall Scraper Replacement Blades (100 blades)



10-296

CARPET PULLER

- Unique design provides maximum pulling power
- Serrated clamps provide firm carpet grip, great for removing carpet
- Large comfortable handle
- Die-cast aluminum



10-10

BASE MOLDING LIFTER

- Perfect angles provide ideal leverage for removing base molding and tackstrip
- New deep bevel nail slot for easy nail removal
- Constructed from high carbon forged steel with bright nickel plating
- Upgraded deep bevel slots for easy nailing
- 10-1/2" long

- 10-510-3** Base Molding Lifter
- 10-512B** Base Molding Lifter (Bulk, 36 pcs. per case)



10-510-3

BANG-IT ULTIMATE DOOR HINGE PIN REMOVER

- Easy-to-use nickel plated, hardened steel tool minimizes damage to surrounding area
- Wedge end forces pin head up; steel pin end drives pin through hinge plates



10-519

*Refer to page 33 for a complete listing of replacement blades.

STAPLERS



10-600

PROFESSIONAL ELECTRIC STAPLER

- Powerful, 15 amp solenoid delivers more power to drive staples deeper
- 6-3/4" low profile head allows easy access in tight places, particularly stairs
- Heavy 14 gauge, 12ft. power cord offers maximum power and provides a wider range of travel without extension cords
- Hardened driver mechanism that shoots 20 gauge, 3/16" crown staples
- Quick-release bottom loading magazine for fast reloading (85 staple capacity)
- Ergonomic non-slip handle with rubber grip for maximum comfort and control
- Includes custom molded carrying case
- Accepts Duo-Fast® #5418-D Staples and other quality brand 9/16" Divergent Point Staples



10-110-3

HEAVY DUTY HAMMER TACKER

- Perfect for carpet pad, insulation, roofing and more
- Precision built, heavy duty tacker
- Long handle and heavy head delivers perfect staple transfer
- Drives staple lengths of 5/16" to 9/16"
- Two full strip staple capacity
- Comfortable non-slip rubber handle
- Accepts Duo-Fast® 7500 Series staples and other quality brands in 5/16", 3/8", 1/2" and 9/16" lengths



10-109

STAPLE HAMMER

- Perfect balance, durable stamped steel, comfortable vinyl grip, and easy back-end loading
- Accepts 3/8" staples
- Holds 160 staples

30-210 3/8" Divergent Point Staples 5000/bx 20/cs
30-110 3/8" Chisel Point Staples 5000/bx 20/cs

INSTALLATION TOOLS

DUAL LAMINATED SHARPENING STONE

- Quickly sharpens knives and shears
- Large non-slip comfort handle
- Two stones: fine grit on one side, medium grit on the second side
- 10-1/4" stone - 14-7/8" overall



10-756

SHARPENING STONE

- Provides razor sharp edge in seconds
- Sharpens knives and shears
- 180 grit 10" stone



10-131

KNIFE SHARPENER

- Carbide sharpening tip
- Renews factory edge
- Pocket-size
- Vinyl grip and cap
- 4" long



10-133

DELUXE GRIP POUCH

- Holds tools firmly in place with special leather insert grips
- Professionally constructed of 100% leather and double stitching
- Slotted to fit directly on the belt
- 7-1/2" x 4-1/2" x 3/4"



10-260

LEATHER TOOL POUCH

- Sturdy 100% leather with double stitching
- Ideal for carrying knives and other tools
- Slotted to fit directly on the belt
- 7-1/2" x 4-1/2" x 3/4"



10-261

24" STEEL TOOL BOX



Seaming Plate



Staple Storage

- Heavy duty steel construction
- Durable full length piano style hinge
- Strong side handles and durable soft grip lid handle for easy carrying
- Vented nylon seaming plate mounted under tray acts as seaming weight
- Tray provides extra storage for staple and nail boxes
- 3 hardened steel hasps provide secure closure and accept padlocks for additional security
- Baked-on black enamel paint finish
- 24" W x 9-3/4" H x 8-3/4" D

10-161

CARPET INSTALLATION TOOL KIT



Includes:

- 10-161 24" Steel Tool Box
- 10-169 Loop Pile Seam Roller
- 10-108 Professional 2" Strip Cutter
- 10-110-3 Heavy Duty Hammer Tacker
- 10-114 20 oz. Ripping Hammer
- 10-146GT GT Cushion Back Cutter
- 10-151 Nail Driving Bar
- 10-152GT GT Loop Pile Cutter
- 10-215 Razor Blade Knife
- 10-261 Leather Tool Pouch
- 10-303S Thriftline Chalk Reel
- 10-321 White Chalk Refill - 8 oz.
- 10-412-2 Deluxe Knee Kicker
- 10-510-3 Base Molding Lifter
- 10-521 3-1/2" Extra Wide Stair Tool
- 10-522-4 EZ Tuk Carpet Tucker
- 10-586-3 Duckbill Napping Shears
- 10-616-2 Conventional Carpet Cutter
- 10-920-6 Pro Fixed Blade Utility Knife
- 10-931 Linoleum Knife
- 10-140 30' Tape Measure
- 10-517 Row Finder
- 61613 Rubber Mallet

10-750

10-750 Carpet Installation Tool Kit

INSTALLATION TOOLS

DELUXE HOT MELT GLUE GUN

- 100 Watts at 400°F
- Works twice as fast as conventional glue guns
- Double powered solid state heater warms up in just 3 minutes
- Extrudes up to 2 lbs. of glue per hour
- Fits easily into carpet seams and hard-to-reach areas with its extra long nozzle
- Spring-loaded trigger eliminates glue back-up and gun damage



10-800

HOT MELT GLUE GUN

- Solid state heating system warms up in just 3 minutes
- Silicone feed sleeve provides smooth application
- Extrudes up to 1 lb. of glue per hour
- Specially designed trigger with feed pressure limiter eliminates glue back-up and gun damage
- 40 Watts at 380°F



10-700

GLUE STICKS

- Excellent for most carpet and sheetgoods excluding vinyl backs
- Make repairs disappear with our translucent hot melt glue stick that cools almost clear
- 1/2" diameter fits most glue guns

- 10-801** 10" Glue Sticks, 25 lb. bulk pack (380 sticks)
- 10-802** 10" Glue Sticks, 12 sticks per box
- 10-701** 4" Glue Sticks, 30 sticks per box
- 10-701B** 4" Glue Sticks, 30 sticks per box, 48 per case



10-801, 10-802, 10-701

FLAMELESS HEAT GUNS

- Bends and softens floor tile, plastic laminates, linoleum, vinyl cove base and molding
- Superior air flow
- Safe, instant heat and circuit breaker protection
- Variable 200°F- 750°F or 600°F- 900°F temperature adjustment
- Lightweight, durable LEXAN® housing
- Sturdy LEXAN stand included

- 10-189** 200°- 750° Flameless Heat Gun
- 10-190** 600°- 900° Flameless Heat Gun



10-189, 10-190

CHALK AND LINE REELS

- Special formula prevents caking and clotting

- 10-3035** Thriftline Chalk Reel
- 10-321** White Chalk, 8 oz.
- 10-331** White Chalk, 5 lbs.
- 10-323** Blue Chalk, 8 oz.



10-3035, 10-321, 10-331, 10-323

INSTALLATION TOOLS



10-151

NAIL DRIVING BAR

- Constructed of cold forged carbon steel for an extra long life
- Features a magnetic head to hold nails in place for easy starting
- Unique design to access hard-to-reach places such as: under radiators, toe kicks, overhangs and next to glass doors when nailing down tackless strip
- Soft, no-slip handle
- 12-3/8" in length



10-108

PROFESSIONAL 2" STRIP CUTTER

- Long jaws cut architectural strip
- Powerful cutting force - 8 to 1 leverage
- Rugged, forged steel construction
- Blade storage in handle

*Uses replacement blades: 10-439**



10-274

10" AVIATION SNIPS

- Extra powerful compound leverage allows effortless metal cutting
- Serrated blades prevent slip-out
- Cut notches and shallow curves as well as straight cuts
- Vinyl covered handles for comfort



10-114

20 OZ. RIPPING HAMMER

- Sturdy, quality hickory construction
- Long straight claw is ideal for pulling up old tack strip
- 20 oz. head
- Contoured handle provides optimal strength while minimizing impact shock
- 13-1/2" long



10-140

30' TAPE MEASURE

- 30' x 1" steel acrylic coated blade
- Rugged case with red rubber jacket
- Bright colors for "easy to find" visibility
- Strong spring return, thumb lock
- Steel belt clip



10-138

100' FIBERGLASS TAPE MEASURE

- Fully enclosed case, 100' fiberglass reinforced tape, steel end hook
- Folding retracting crank
- Tape resists stretching; non-conductive; coated to resist abrasion
- Tough ABS case with rubber hand grip

*Refer to page 33 for a complete listing of replacement blades.

INSTALLATION TOOLS

CARPET GROOMER

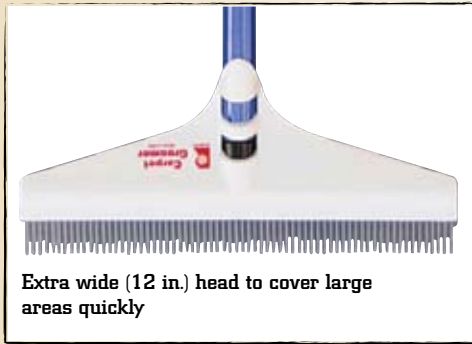

Extra wide (12 in.) head to cover large areas quickly

- Raises trapped-in dirt and loosens embedded pet hair for easy removal
- Revitalizes carpet quickly without vacuuming
- Revives crushed and matted carpet
- Makes vacuum track marks disappear

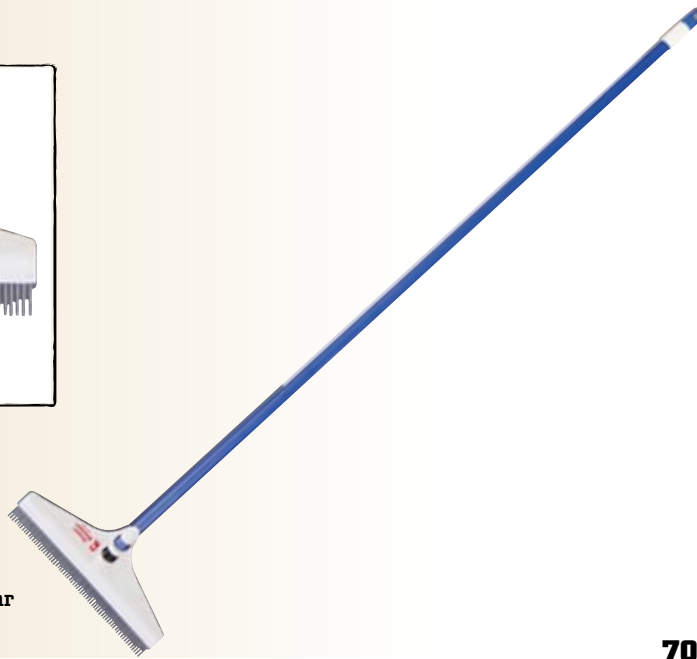

70-125

HARD CAP KNEE PADS

- Hard cap glides easily on soft flooring
- Nylon fabric with foam cushion
- Adjustable Velcro® straps



79023

WALL BASE ADHESIVE/CAULK APPLICATOR GUN

- All steel construction
- Smooth rod push mechanism
- Holds 30 oz. cartridge



10-980

"SNOZZLE" ADHESIVE APPLICATOR

- Exclusive design spreads 11 rows of adhesive
- Creates a flat, well-bonded installation
- Fits all standard open end caulking guns
- Works with both 11 oz. and 30 oz. cartridges



10-981-25

TOPSET GOUGE (CANADA ONLY)

- Grooves the back of vinyl or rubber cover base to allow the material to be tightly wrapped around corners
- 5/32" wide blade adjusts for depth and can be sharpened



10-279

"ACTION GRIP" CUSHION HANDLE



Professional Series

- Contoured Action Grip Handle
- Premium Polished Spring Steel Blade provides perfect "blade flex"
- Durable aluminum casting
- 9 flush finish stud welded rivets
- 4-1/2" x 11" and 4-1/2" x 16" trowel blades

11" Blades

- 10-823** 1/16" x 1/16" x 1/16" (SQ), 10° angle
- 10-824** 3/16" x 3/16" x 3/16" (SQ)
- 10-825** 1/4" x 1/4" x 1/4" (SQ)
- 10-826** 1/8" x 1/8" x 1/8" (SQ)
- 10-827** 1/4" x 1/8" x 1/4" (SQ)
- 10-828** 1/8" x 3/16" x 1/8" (U)
- 10-829** 1/16" x 1/32" x 1/32" (U), 10° angle
- 10-831** 1/8" x 1/8" x 1/8" (U)
- 10-832** 1/4" x 1/8" x 1/4" (U)
- 10-833** 3/32" x 3/32" x 3/32" (Flat-Top V), 10° angle
- 10-834** 1/8" x 1/8" x 1/16" (Flat-Top V)
- 10-835** 3/16" x 1/4" x 5/16" (Flat-Top V)
- 10-837** Finishing Trowel

16" Blades

- 10-844** 1/16" x 1/16" x 1/16" (SQ)
- 10-845** 1/16" x 1/32" x 1/32" (U)
- 10-847** Finishing Trowel
- 10-849** 3/32" x 3/32" x 3/32" (Flat-Top V)

ECONOMY TROWELS



- 10121-12** 1/16" x 1/16" x 3/32" (U)
- 10122** 1/16" x 1/32" x 5/64" (U)
- 10123-12** 1/8" x 1/8" x 1/8" (SQ)
- 10125** 1/16" x 1/16" x 1/16" (SQ)
- 10137-12** 1/8" x 1/8" x 1/16" (Flat-Top V)
- 10142-12** 1/4" x 1/4" x 1/4" (Flat-Top V)

"CAMEL BACK" WOOD HANDLE



Contractor Series

- Wood contoured grip handle
- Premium Polished Spring Steel Blade provides perfect "blade flex"
- Durable aluminum casting
- 9 flush finish stud welded rivets
- 4-1/2" x 11" and 4-1/2" x 16" trowel blades

11" Blades

- 10-810** 1/16" x 1/16" x 1/16" (SQ), 10° angle
- 10-811** 3/16" x 3/16" x 3/16" (SQ)
- 10-812** 1/4" x 1/4" x 1/4" (SQ)
- 10-813** 1/8" x 1/8" x 1/8" (SQ)
- 10-814** 1/4" x 1/8" x 1/4" (SQ)
- 10-815** 1/8" x 3/16" x 1/8" (U)
- 10-816** 1/16" x 1/32" x 1/32" (U), 10° angle
- 10-818** 1/8" x 1/8" x 1/8" (U)
- 10-819** 1/4" x 1/8" x 1/4" (U)
- 10-820** 3/32" x 3/32" x 3/32" (Flat-Top V), 10° angle
- 10-821** 1/8" x 1/8" x 1/16" (V)
- 10-822** 3/16" x 1/4" x 5/16" (Flat-Top V)
- 10-836** Finishing Trowel
- 49732** 1/8" x 1/8" x 1/8" (SQ)
- 49736** 1/16" x 1/16" x 3/32" (U)
- 49737** 1/8" x 1/8" x 1/16" (Flat-Top V)
- 49738** 1/16" x 1/32" x 5/64" (U)
- 49739** 1/4" x 1/4" x 1/4" (Flat-Top V)

16" Blades

- 10-842** 1/16" x 1/16" x 1/16" (SQ)
- 10-843** 1/16" x 1/32" x 1/32" (U)
- 10-846** Finishing Trowel
- 10-848** 3/32" x 3/32" x 3/32" (Flat-Top V)

WALL BASE TROWELS

- 10033** 3/16" x 5/32" (Flat-Top V)



TROWELS

Square Notch

1/16" x 1/16" x 1/16"

10-823 10-842
10-844 10-125-11
10-810 10125

3/16" x 3/16" x 3/16"

10-824
10-811

1/4" x 1/4" x 1/4"

10-825
10-812

1/8" x 1/8" x 1/8"

10-826 49732
10-813 10123-12

1/4" x 1/8" x 1/4"

10-827
10-814

U-Notch

1/8" x 3/16" x 1/8"

10-828
10-815

1/16" x 1/32" x 1/32"

10-829
10-816

1/8" x 1/8" x 1/8"

10-831
10-818

1/4" x 1/8" x 1/4"

10-832
10-819

1/16" x 1/16" x 3/32"

49736 10121-12

1/16" x 1/32" x 5/64"

49738 10122

V-Notch

3/32" x 3/32" x 3/32"

10-833 10-848
10-849
10-820

1/8" x 1/8" x 1/16"

10-834 49737
10-821 10137-12

3/16" x 1/4" x 5/16"

10-835
10-822

1/4" x 1/4" x 1/4"

49739 10142-12

Finishing Trowel

10-837 10-847
10-836 10-846

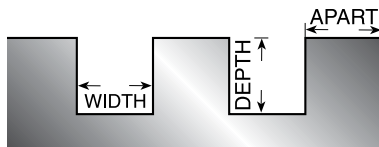

†All Trowels Measure: Width x Depth x Space Apart

* Recommended Notch Sizes by Carpet and Rug Institute CRI® 105-2002

*Refer to the QEP Catalog for a complete list of ceramic trowels.

HEAVY DUTY LINOLEUM/CARPET ROLLERS



10-952-04

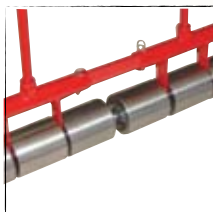

10-952-06



- Detachable transport wheel assembly kit for easy transport, upright support, and protection of segmented rollers
- Chrome-plated segmented rollers exert even pressure on uneven surfaces
- Inset axles won't scuff walls
- 30" removable handle for convenient storage



10-950, 10-952

- 10-950** 75 lb. Roller
- 10-952** 100 lb. Roller
- 10-952-04** Transport Wheel Assembly Kit
- 10-952-06** Linoleum Roller Connector Tube

LIGHTWEIGHT 35 LB. ROLLER

- Lightweight, easy to carry on and off the job
- Ideal for "double glue" installations
- Chrome-plated segmented rollers exert even pressure on uneven surfaces
- Inset axles won't scuff walls
- 30" removable handle for convenient storage



10-935

EXTENDIBLE FLOOR ROLLER

- Great for rolling vinyl floor covering, carpet and cove base
- Handle extends from 17" to 27"
- Segmented rollers exert even pressure on uneven surfaces
- 7-3/8" wide non-marking rollers and inset axles won't scuff walls
- Second handle for additional leverage



10-955

18" VINYL TILE CUTTER

- Moveable cutting guide for consistent and accurate repetitive cutting of Vinyl Composition Tile (VCT)
- Built-in casters for greater maneuverability and rubber feet for added stability
- Clearly marked measuring guide and 45° miter guide
- Includes durable nylon carrying case complete with two 5-1/2" x 7" pouches for smaller tools
- Cuts 18" tiles or 12" tiles diagonally
- Extended two-year warranty



10-918-40 Replacement Carrying Case

10-918

12" VINYL TILE CUTTER

- Moveable cutting guide for consistent and accurate repetitive cutting of Vinyl Composition Tile (VCT)
- Built-in casters for greater maneuverability and rubber feet for added stability
- Clearly marked measuring guide and 45° miter guide
- Includes custom blow molded carrying case
- Cuts 12" tiles or 9" tiles diagonally
- Extended two-year warranty

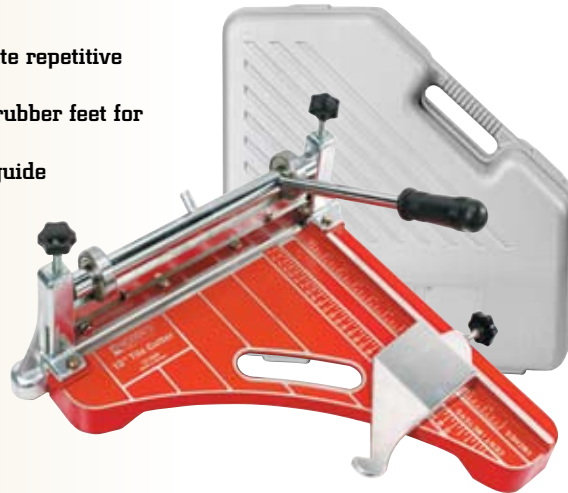

10-900-22 Replacement Carrying Case

10-900

QUIK-CUT VINYL TILE CUTTER

- Cuts vinyl tile up to 12" x 12"
- Ball bearing at stress points
- Ball and needle bearings for long life and precise operation
- Built-in measuring gauge
- Hardened steel blades
- Die cast aluminum base



30002

VCT SEAM ROLLER

- Use to roll seams on VCT and sheet vinyl
- Rounded outside edge
- 2" x 2" polished steel rollers mounted on 2 smooth rolling ball bearings
- Case hardened brackets resist axle wear
- Wood handle shaped for comfort



10-960



10-575

HEAVY CARGO DOLLIES

- These rugged, durable movers are perfect for moving rolls of carpet or sheet goods, equipment, furniture and appliances
- Each dolly holds up to 1000 pounds
- Made from heavy industrial steel, with welded and bolted construction
- Easily extends from 24" to 33" with spring loaded lock pins
- Heavy-duty 3" ball bearing non-mar polyurethane wheels



10-227

KARPET KART

- Super tough heavy gauge tubular steel and all welded construction
- Features 16" pneumatic tires
- 1000 pound capacity
- 61" L x 20-1/4" W x 18-1/2" H

10-227-02A Karpet Kart Replacement Wheels



10-480

DUAL AIR GLIDER

- A powerful, lightweight mechanism which utilizes hovercraft principles for easy and safe movement of commercial and industrial machinery, office equipment and household appliances without damaging floors
- 8-1/2" x 36" dual vacuum platforms
- 1.75 HP blower provides a 750 lbs. lift capacity
- Improved motor output connector
- Includes carrying case



10-50, 10-51

E-Z SLIDES

- Helps easily move heavy furniture and appliances
- Super slick high density plastic slides have closed-cell, non-skid foam pads
- Includes heavy-duty metal grommets for pulling

10-50 Set of 2 slides: 6-3/4" wide x 48" long
10-51 Set of 4 slides: 6-3/4" wide x 11-1/2" long (not shown)



10-228

CARPET ROLL LIFTER

- Provides the "muscle" needed to lift and load rolls of carpet
- Easy for one person to use
- 1200 pound capacity

LAMINATE TOOLS

FLOOR BOAR LAMINATE CUTTER

- Cuts planks up to 12mm thick
- Innovative ratchet action handle continuously feeds planks into the cutting blades
- Works with all brands of laminate with or without attached padding
- Cuts planks to any length including cross cuts, notch cuts and angle cuts - no electricity needed
- Non-slip rubber feet for extra grip
- Dual 48-tooth hardened steel blades for long lasting use
- Solid steel reinforced base for stability



10-452-A Replacement Saw Blades (set of 2)

Rip Cuts

10-452

8" LAMINATE CUTTER

- Cuts laminate up to 8 in. wide and 12mm thick
- Heavy duty steel frame for maximum stability
- Positionable "V" support keeps planks level while cutting



10-35

FLOORING INSTALLATION KIT

- For installing glue or glueless laminate and hardwood flooring
- Kit contains: 30 Spacers, Tapping Block, Pull Bar

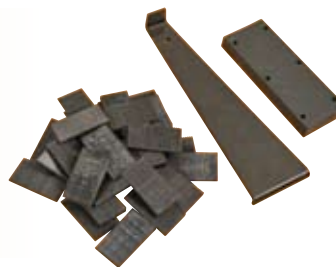

10-26

PRO PULL BAR

- Used to install all brands of tongue and groove flooring
- Premium steel construction
- Precise angles allow pull bar to be easily tapped while firmly gripping flooring to create seamless joints
- Soft felt backing protects floors from scratches during installation
- 16-1/4" long



10-18-8

TAPPING BLOCK

- Used to install all brands of tongue and groove flooring
- High density polypropylene base provides extended product life
- 20" profile equally distributes maximum tapping force
- Comfortable large grip handle
- 20" long



10-17-8

LAMINATE WEDGE SPACERS

- Used to create a perimeter expansion gap when installing laminate and other floating floors
- Prevents the flooring from moving during installation
- 30 wedges per bag



10-27

UNDERLAYMENT

HARMONY®

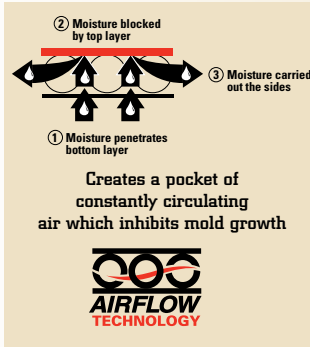

- Sound resistant underlayment for use under all laminate and engineered hardwood floating floors
- IIC rating of 68 and STC rating of 67
- Excellent moisture resistant barrier
- Reduces ambient noise
- 8" overlap with adhesive strip for installation
- Outstanding compression resistance over time
- Ideal for basements, condos and multi-level dwellings

70-100-12

70-100-1 (630 ft. roll)
70-100-12 (12 - 100 ft. rolls)



QUIET CUSHION

- Progressive Foam Technology (PFT) designed for supreme sound reduction
- Extra fine, cross linked foam for advanced moisture protection and shock absorption
- Excellent for radiant heat floors
- Mold and mildew resistant
- Anti-crush technology for excellent performance and long life
- Includes adhesive strip and 3" overlap film for linking multiple rolls
- For use under engineered and laminate flooring

70-180

70-180 (100 sq. ft. roll)



SOFT STRIDE

- Dense foam provides excellent sound reduction under engineered and laminate flooring
- Closed cell foam for excellent moisture protection
- Excellent for radiant heat floors
- Mold and mildew resistant
- Anti-crush technology for excellent performance and long life
- 2 mm thick foam, cushions flooring
- Includes adhesive strip and 3" overlap film for linking multiple rolls

70-185

70-185 (100 sq. ft. roll)



SUPER FELT

- Provides deep, rich sound by absorbing noise instead of deflecting it
- Made from recycled fibers
- Extremely high temperature manufacturing process disinfects and treats fibers
- 4mm thick pad correct minor sub-floor imperfections
- Added R-Value to chilly floors
- Includes adhesive strip and 3" overlap film for linking multiple rolls
- For use under engineered and laminate flooring

70-190

70-190 (100 sq. ft. roll)

UNDERLAYMENT

UNISON™ 2-IN-1 UNDERLAYMENT

- 3/32" polyethylene foam increases cushioning between flooring and subfloor
- 3" film overlap with adhesive strip for seamless protection
- 2 mil. thick top film protects from harmful moisture vapor



70-025

70-025 (100 sq. ft. roll)

SERENITY FOAM UNDERLAYMENT

- 3/32" polyethylene foam underlayment for laminate and engineered wood flooring
- Ideal for above grade uses
- Corrects minor subfloor imperfections



70-010

70-010 (100 sq. ft. roll)

MOISTURE BARRICADE

- Use with standard foam underlayments to protect against moisture
- 6 mil. thick polyethylene film for long life
- Roll unfolds to cover an extra large 10' x 12' area
- Use with laminate flooring with pre attached underlayment



70-115

70-115 (120 sq. ft. roll)

WAXED PAPER ROLL (CANADA ONLY)

- High quality 30-lb. heavy duty Kraft paper for professional performance
- Use as a barrier between wood subfloor and new floor on above grade installations
- Helps in reducing squeaks in plywood subfloors
- Waxed on both sides for use with hardwood or engineered nail-down installations
- Use to slide boards into place with ease



70-120

70-120 (750 sq. ft. roll)

NATURAL CORK UNDERLAYMENT

- Reduces sound transmission from both the surface of a floor as well as through the floor to living spaces below
- Use under ceramic tile, stone, marble, engineered hardwood and laminate floors
- Acts as a crack isolation membrane that resists transfer of stress cracks from subfloor through to flooring surfaces
- Reduces thermal transmission, increasing the effectiveness of floor heating systems
- Easy to install in both glue-down and loose-lay configurations



72000, 72001

72000 (1/4" or 6mm Cork Underlayment Roll, Coverage: 200 sq ft / roll, Dimensions: 48" x 50' x 1/4", 1 roll/case)

72001 (1/2" or 12mm Cork Underlayment Sheets, Coverage: 6 sq ft / sheet, Dimensions: 2' x 3' x 1/2", 25 sheets/case)

72004 (4mm Cork Underlayment Sheets, Coverage: 456 sq. ft. / case, Dimensions: 2' x 3' x 1/2", 76/case) - CANADA ONLY

72025 (2.5mm Cork Underlayment Sheets, Coverage: 720 sq. ft. / case, Dimensions: 2' x 3' x 1/2", 120/case) - CANADA ONLY

72006 (6mm Cork Underlayment Sheets, Coverage: 312 sq. ft. / case, Dimensions: 2' x 3' x 1/2", 52/case) - CANADA ONLY

* Refer to page 29 for laminate tools.

SURFACE PROTECTION & TAPE



TEMPORARY CARPET PROTECTION

- Protects - use as a temporary shield over carpeting (except wool)
- Reverse wound for extra convenience
- Consumer friendly - 50 foot rolls are great for shelf displays
- Individually boxed - informative box for easy sell-through

70-130	24" x 50' (100 sq. ft.) / 20 per Display Case
70-140	24" x 200' (400 sq. ft.) / Individually Boxed
70-150	36" x 250' (750 sq. ft.) / Individually Boxed
70-160	36" x 500' (1500 sq. ft.) / Individually Boxed

70-130 / 70-140 / 70-150 / 70-160



HARD SURFACE PROTECTIVE FILM

- Ideal for hard floors including tile, wood and vinyl
- Protects from dirt and stains in high traffic areas
- Easy to roll on and remove
- 30 day temporary use
- 100 sq. ft. roll (24" x 50')

70-145



DOUBLE-SIDED ACRYLIC ADHESIVE STRIP FOR VINYL

- For modified loose lay vinyl sheet flooring installation
- Odor free adhesive and no clean up required
- Great for flooring repairs

50-540

50-540 (1 7/8" x 50') / Individually Boxed



DOUBLE-SIDED ACRYLIC ADHESIVE STRIP FOR CARPET

- For the installation of carpet, moldings & trim
- Works on indoor and outdoor installations
- Ideal for stair treads

50-550 (1 7/8" x 75') / Individually Boxed
50-560 (1" x 164') / Individually Boxed
50-565 (3" x 164') / Individually Boxed
50-570 (9" x 164') / Individually Boxed

50-550, 50-560, 50-565, 50-570

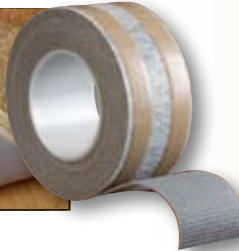

TRACTION NON-SLIP RUG STRIP

- Non-slip rug strip is specifically designed for holding rugs and mats in place
- One side attaches permanently to the rug and the other side features a non-slip surface
- Easy to apply and requires no clean up

50-545

50-545 (2 1/2" x 25') / Individually Boxed

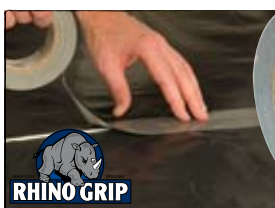

DUCT TAPE

- Great for general repairs, projects, packing, seaming and sealing
- Easily tears by hand
- Conforms easily to uneven surfaces

50-555

50-555 (1 7/8" x 60 yds) / Individually Boxed

1-866-435-8665

HEAVY DUTY SLOTTED BLADES (BLUE)



Fits Roberts 10-146-3, 10-146GT Cushion Back Cutter, 10-147 Cushion Back Cutter with Row Finder, 10-152-3, 10-152 GT Loop Pile

Cutter, 10-154 Loop Pile Cutter, 10-215 Razor Blade Knife, 10-220 Cut & Jam Carpet Knife, 10-905 Multi-Purpose Wall Trimmer, and most other brands.

Blade Specifications: 2.25" long x .017" thick

- 10-436** 10 Blade Blistercard 10 cards/case (100 blades)
- 10-437** 10 Blade Blistercard 100 cards/case (1000 blades)
- 10-438** 100 Blade Pack - Bulk 10 packs/case (1000 blades)

HEAVY DUTY UTILITY BLADES



Fits Roberts 10-203, 10-208, 10-218 and 10-920-6 Utility Knives, and most other brands.

Heavy Duty Blade Specifications: 2.28" long x .025" thick

- 10-434** 100 Blade Pack - Bulk 10 packs/case (1000 blades)

TRIMMER BLADES



Fits Roberts 10-154 Loop Pile Cutter, 10-616 GT Conventional Carpet Trimmer, 10-920-6 Professional Utility Knife, and most other brands.

Blade Specifications: 2.125" long x .017" thick

- 10-388** 100 Blade Pack - Bulk 10 packs/case (1000 blades)



Fits Roberts 10-154 Loop Pile Cutter, 10-616 GT Conventional Carpet Trimmer, 10-920-6 Professional Utility Knife and most other brands.

Blade Specifications: 2.18" long x .017" thick

- 10-444** 10 Blade Blistercard 10 cards/case (100 blades)
- 10-445** 10 Blade Blistercard 100 cards/case (1000 blades)

HOOKED BLADES



Fits Roberts 10-905 Multi-Purpose Wall Trimmer.

Blade Specifications: 1.84" long x .025" thick

- 10-440** 10 Blade Blistercard 10 cards/case (100 blades)
- 10-441** 10 Blade Blistercard 100 cards/case (1000 blades)

STRIP CUTTER BLADES



Fits Roberts 10-108 Strip Cutter.

Blade Specifications: 1.86" long x .45" wide x .038" thick

- 10-439** 6 Blade Blistercard 10 cards/case (60 blades)

4" FLOOR/WALL SCRAPER BLADES



Fits Roberts 10-194, 10-294 Floor Scraper and most other brands.

Blade Specifications: 4" long x .015" thick

- 10-442** 10 Blade Blistercard 10 cards/case (100 blades)
- 10-457** 100 Blade Pack - Bulk 10 packs/case (1000 blades)

8" FLOOR/WALL SCRAPER BLADES



Fits Roberts 10-296 Stand-Up Scraper, and most other brands.

Blade Specifications: 8" long x 0.74" wide x .035" thick

- 10-458** 10 Blade Tube 1 tube (10 blades)
- 10-458B** 10 Blade Tube 10 tubes/case (100 blades)

4" DOUBLE-SIDED SCRAPER BLADE (SEE PAGE 16)

Fits Roberts 10-196 Heavy Duty 4" Scraper (see page 16).

Blade Specifications: 4" x 4"

- 10-455** 1 Blade Clamshell 12 clamshells/case (12 blades)

6" HEAVY DUTY SCRAPER BLADE

Fits Roberts 10-195 Heavy Duty Convertible Scraper (see page 16).

Blade Specifications: 6" long x 4" wide

- 10-195-01** 6" Heavy Duty Scraper Blade (1 blade)

STRIPPER MACHINE BLADES

Fits Roberts 10-475 Stripper (see page 16).

- 10-475-50** 4" x 4" Double Sided Blade
- 10-475-51** 4" x 6" Double Sided Blade



10 GAUGE CONCRETE NAILS

A heavy 10-gauge shank nail for use on extremely hard or "aged" concrete.

- 33-100** 5/8" Concrete Nails 1 lb. Bag 10/cs
- 33-101** 5/8" Concrete Nails 1 lb. Bag 25/cs
- 33-103** 5/8" Concrete Nails 5 lb. Bag 5/cs
- 33-106** 5/8" Concrete Nails 50 lb. Bulk



CHISEL POINT STAPLES

Get jam-proof efficiency with its "V" shaped points that drive easily into most wood floors.

- 30-110** 3/8" Staples 5000/bx 20/cs



DIVERGENT POINT STAPLES

Easily penetrate vinyl tile, linoleum, felt and wood (including hardwoods) with its 60° point. Get added holding power when staple legs veer in opposite directions.

- 30-210** 3/8" Staples 5000/bx 20/cs





Corporate Office

1001 Broken Sound Parkway, NW
Suite A
Boca Raton, FL 33487
p 561-994-5550 f 561-241-2830

Roberts proudly stands behind all its products with outstanding Customer Service, Technical Service, and a variety of supporting literature.

Customer Service

- The best in the industry

Expert Technical Support

- Problem Solving
- Site inspections

For assistance in the U.S. call toll-free:

1-866-435-8665

For assistance in Canada call toll-free:

1-800-840-9422

Technical and Product Literature

Easy access to product data sheets and MSDS sheets 24 hours a day, 7 days a week through our continuously updated website:

www.robertsconsolidated.com

1-866-435-8665

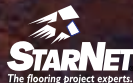

Printed 2010